

THULE Ocean 100

689/653008 (Thule GmbH no.) 3071-350-842 (Thule AB no.)

5 *års garanti*
years warranty
Jahre Garantie
ans de garantie

Technical approval:

TÜV/GS DIN 75302 (Germany).

Materials:

Special UV-protected and impact resistant box material.

Colour:

Lid - Grey

Bottom - Anthracite

Method of manufacture:

Vacuum forming.

Assembly:

Easy-Snap-80 mm mounting system, hole pattern front and rear. Carrier bar distance 450-900 mm.

Dimensions/Weight:

Length: 1390 mm

Width: 905 mm

Height: 390 mm

Volume: 360 litres

Weight: 12 Kg

Load:

Maximum load: 50 kg. Observe vehicle manufacturers instructions and maximum roof load.



- Single side opening system.
- Special UV-protected and impact resistant box material.
- Dual-Force lid opener.
- TÜV/GS-approved.
- Central locking system.
- Easy-Snap-80 mm mounting system, hole pattern front and rear.
- Featuring THULE's One Key System. 

THULE Ocean 100

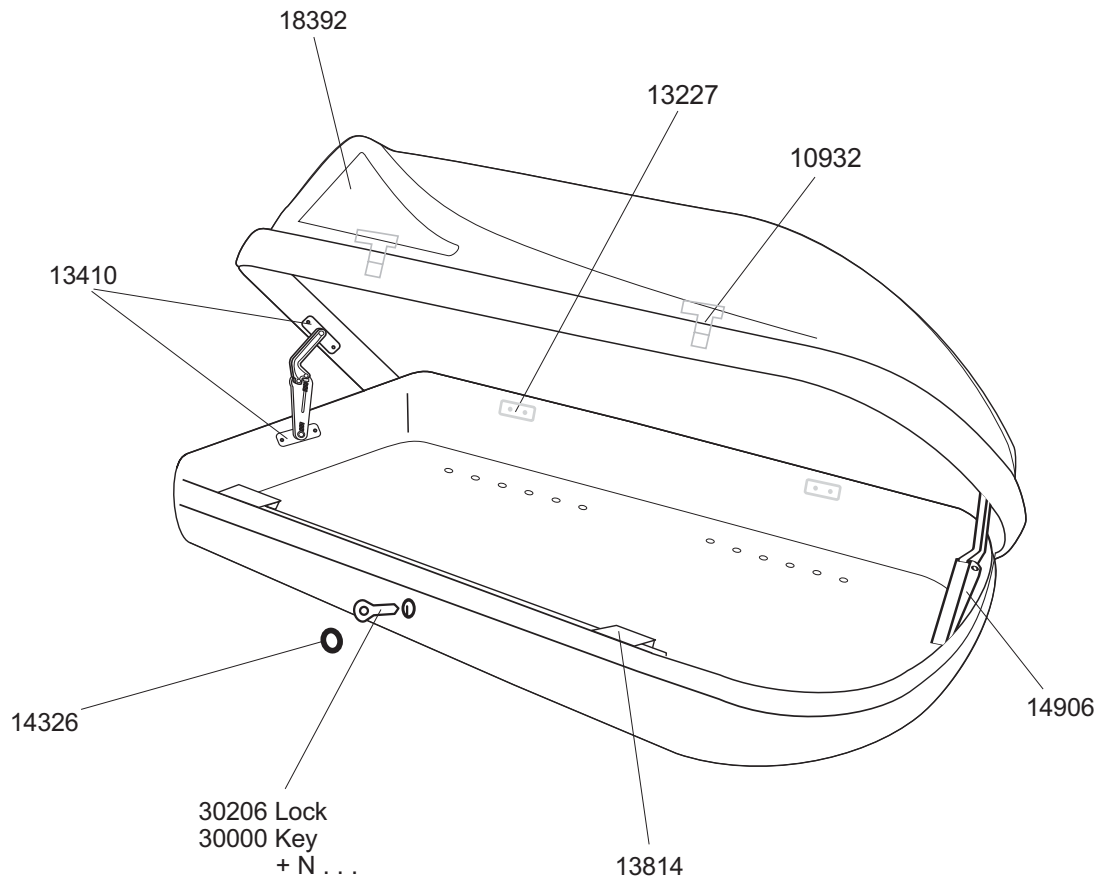

10739

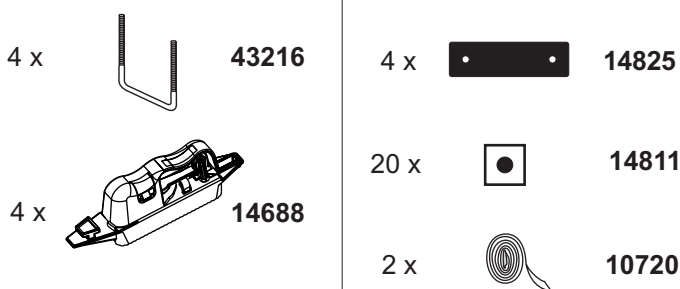

Packing

Product	EAN	Kg	L/W/H in cm
689	4002253653008	14	142/104/42

Product	Packs/Trailer
689	110